



4" END PORT PRESSURE VESSEL

TECHNICAL MANUAL

BEL COMPOSITE IBERICA S.L.

Parque Tecnológico Fuente Álamo. Ctra. del Estrecho-Lobosillo, km 2.
30320 Fuente Álamo, Murcia, Spain – CIF B30781215

Tel.: +34 968 197 501 | FAX: + 34 968 197 502 | www.belvessels.com | iberica@bel-g.com

May, 2020 - Rev.3 - Page 0 of 29

Introduction

BEL, founded in 1966, specializes in the design and manufacture of a variety of products made from advanced composite materials. With over 50 years of experience, the company has developed and mastered the innovative technologies necessary to manufacture the highest quality composite products. Combining innovation, technology, responsibility and dedication, our goal is to become the leader in providing commercial and industrial composite vessels for our clients needs.

BEL pressure vessels are manufactured from filament wound fiber reinforced plastic (FRP), wound over precision mandrels, using a superior epoxy resin, which results in the ultimate combination of physical strength and an ultra smooth inside surface. Vessels are tested according to the requirements of ASME code section X, the internationally recognized standard for pressure vessel construction.

BEL holds ISO 9001 quality systems certification, and its quality assurance is also approved for in-house final inspection by many of its customers.

The BEL family of pressure vessels is designed to be used as housings for all 4", 8", 9" and 16" inch spiral-wound Reverse Osmosis (RO), Nanofiltration (NF) and Ultra filtration (UF) membrane elements.

The pressure vessels are manufactured in different configurations, according to the required operating pressures, filtration type, and piping layout. In order to enhance interchangeability and facilitate the use and maintenance of the vessels, the utilization of identical parts and sub-assemblies has been maximized throughout the design of the vessel. For better performance and longer service life, each model is manufactured from the highest quality and highest performing materials of construction.

TABLE OF CONTENTS

1. SAFETY PRECAUTIONS	3
2. INSTALLATION NOTES	4
3. COMPONENT LIST	5
3.1.- BEL 4" Pressure vessel 300 psi. End Port type.....	5
3.2.- BEL 4" Pressure vessel 450 psi. End Port type.....	6
3.3.- BEL 4" Pressure vessel 600 psi. End Port type.....	7
3.4.- BEL 4" Pressure vessel 1000 psi. End Port type.....	8
3.5.- BEL 4" Pressure vessel 1200 psi. End Port type.....	9
3.6.- BEL 4" Pressure vessel 1500 psi. End Port type.....	10
4. MAINTENANCE	11
4.1.- Opening the vessel	11
4.2.- Visual inspection.....	13
Component inspection	13
Vessel inspection.....	13
4.3.- Closing the vessel.....	14
4.4.- Head disassembly	16
4.5.- Head reassembly.....	19
4.6.- Loading the membrane elements.....	23
ANNEX 1 - BEL Puller For 4" pressure vessels heads extraction.....	24
ANNEX 2 - BEL Pusher For 4" and pressure vessels heads installation.....	25
ANNEX 3 - Shimming procedure	26
ANNEX 4 - O-Ring replacement and scratches treatment procedure	28

1. SAFETY PRECAUTIONS

1.1. BEL pressure vessels are designed for high pressure operations. Improper installation, operation service or maintenance may cause severe damage to property, physical injury or death.

1.2. BEL pressure vessels are designed for water treatment only.

PRESSURE AND TEMPERATURE DESIGN LIMITS - Operation of a vessel outside the design limits will make void the warranty and may result in vessel fatigue with possible eventual explosive head failure. Although each vessel is tested at 110% of the design pressure **LONG-TERM OPERATION ABOVE DESIGN PRESSURE MUST BE PREVENTED**. Permeate port pressure **MUST NOT EXCEED 125 psi. (8.6 bar)**. Other options are available, please, consult BEL

1.3. Vessels should **NOT BE OPERATED AT TEMPERATURES ABOVE 65° C (150°F)**.

1.4. The pressure vessel should not be use as a support. Piping manifolds and other fittings should be properly designed system framework. **OPERATING PERSONNEL SHOULD BE DISCOURAGED FROM APPLYING UNDUE FORCE TO ANY FITTINGS CONNECTED DIRECTLY TO A PRESSURE VESSEL.**

1.5. Only qualified mechanics, experienced in working with high pressure hydraulic systems, should be allowed to disassemble or assemble the vessel.

1.6. Regularly inspect the system so as to ensure that the various components have not deteriorated or been damaged. Replace any faulty component, make sure the reason for the fault has been found and fixed as well.

1.7. Make sure that vessels and associated pipe systems are fully depressurized before attempting any service or maintenance operation.

1.8. Be careful not to scratch the inside wall of the shell, especially at the inner sealing area near the groove.

1.9. Corroded parts may cause difficulties in removing the head or other components. Do not try to force remove components before all visible signs of corrosion have been eliminated.

1.10. Inspect end closures regularly; replace components that have deteriorated and correct causes of corrosion.

1.11. Do not tolerate Leaks, or allow end closures to be routinely wetted in any way.

2. INSTALLATION NOTES

- 2.1. Provide adequate room for serving at both ends of vessel. Elements are installed from the upstream end, pushed through towards the downstream end and eventually removed from the downstream end.
- 2.2. Make sure that the vessel is horizontally installed on support saddles. For other installation ways, please consult BEL.
- 2.3. The vessels must not be rigidly clamped in place, mounting design must allow for both radial and axial expansion (typically up to 0.5 mm radial and up to 2-3 mm axial). Restriction can result in damage to the vessel and other system components.
- 2.4. Straps should be tightened enough to hold the vessel onto the support pads. Using a wrench, tighten mounting bolts, but never so tightly (with torque 2-3 Nm) as to restrict expansion.
- 2.5. A flexible piping connection should be provided in order to prevent unwanted loads transfer from the manifolds to the permeate connection and to permit decoupling the header from the vessel.
The recommended permeate port connection is a U-bend pipe with flexible connections at each end.
- 2.6. The piping system must be connected to the ports using flexible connectors in order to allow relative movement of the vessels and the piping system. (Victaulic or equivalent connections are recommended).



End Port	 Spacing [mm]- X	 Max Offset* [mm]	 Max Angle [Deg]
1"	2 - 0.5	2	2

Table 2.1

3. COMPONENT LIST

3.1.- BEL 4" Pressure vessel 300 psi. End Port type.

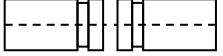
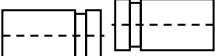

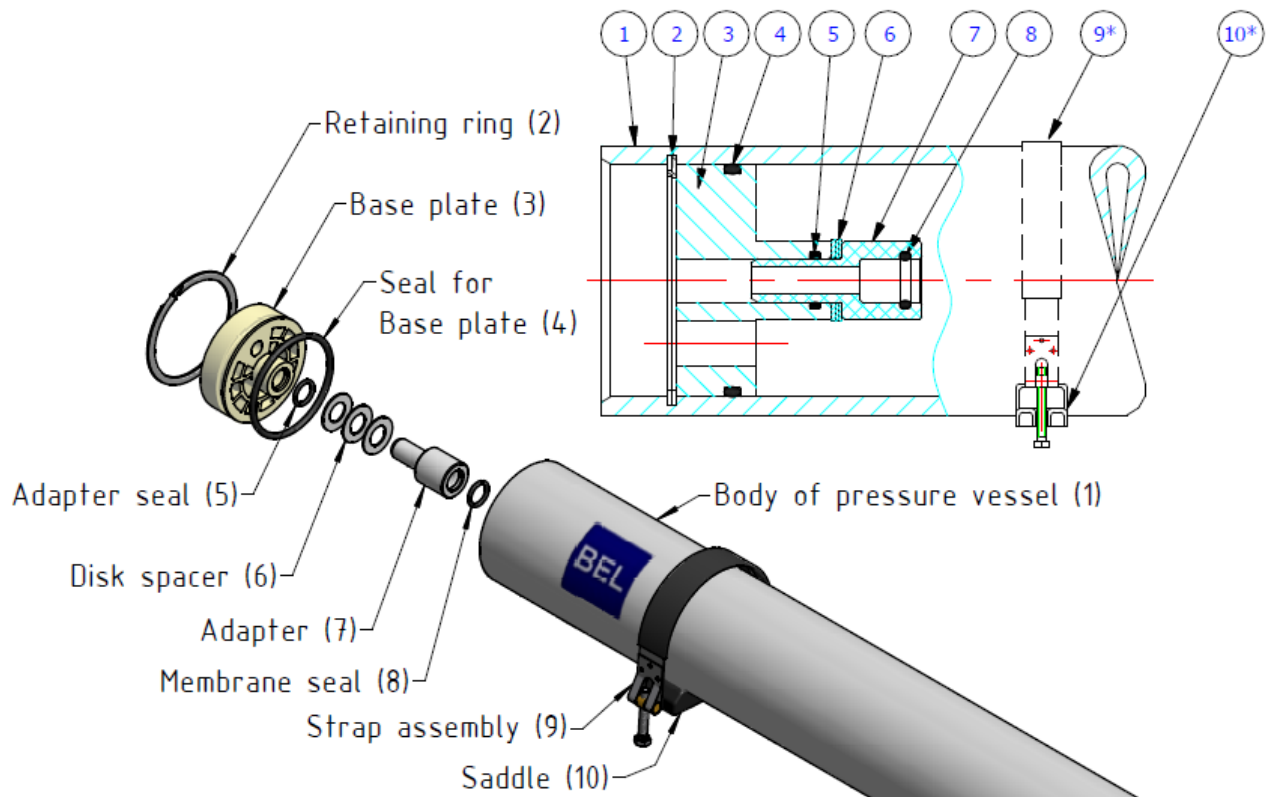
Item	Part number	Q-ty	Description	Material
1	40300-/0..6(12)	1	Body of Pressure vessel	Glass / Epoxy
2	55410208	2	Retaining ring	316 Stainless steel
3	003-400-0003	2	Base plate	Engineering plastic
4	55412360	2	Seal for Base plate	EPDM
5	55412367	2	Seal for Adapter	EPDM
6	55412377	0-6	Disk spacer	Engineering plastic
7	001-075-1200	2	Adapter for Ø 0.75"	Engineering plastic
8	55412367	2	Membrane seal for Ø 0.75"	EPDM
9	55410246	2	Strap assy.	316 Stainless steel
10	55410352	2-3	Saddle	Engineering plastic

Notes:

- 1) Items 9 & 10 are optional. Delivered upon request. Priced separately.
- 2) Number of elements can vary between 1-6 for membrane length of 40", or 1-12 for membrane length of 21".
- 3) Items 6, 7 & 8 are not used for in the vessels with 1 or 2 membrane elements.
- 4) Item 3 corresponds to membrane elements with permeate tube 0.75".
- 5) Items 7 & 8 can be changed to fit more types of membrane permeate tube.
- 6) Item 7 for permeate tube Ø 0.75", part number of Blind adapter - 001-075-1208.

3.2.- BEL 4" Pressure vessel 450 psi. End Port type.

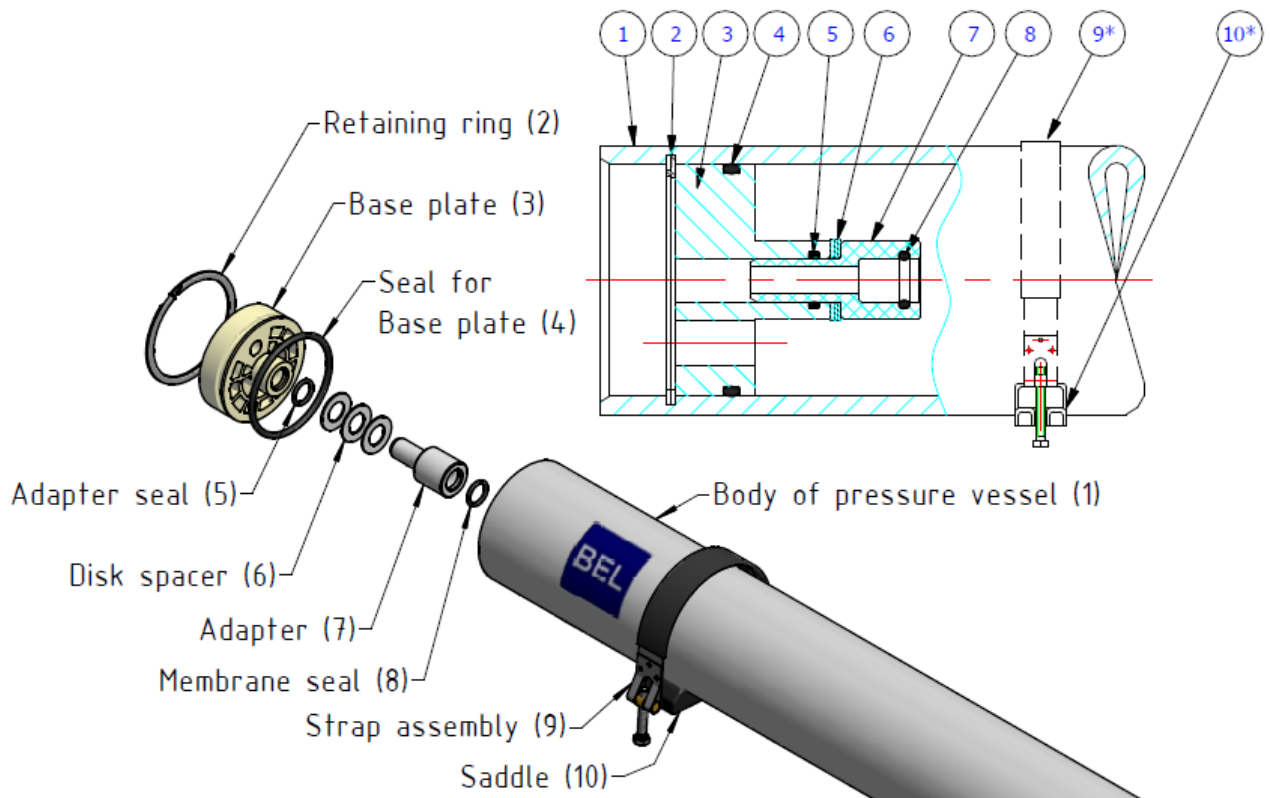

Item	Part number	Q-ty	Description	Material
1	40450-/0..6(12)	1	Body of Pressure vessel	Glass / Epoxy
2	55410208	2	Retaining ring	316 Stainless steel
3	003-400-0003	2	Base plate	Engineering plastic
4	55412360	2	Seal for Base plate	EPDM
5	55412367	2	Seal for Adapter	EPDM
6	55412377	0-6	Disk spacer	Engineering plastic
7	001-075-1200	2	Adapter for Ø 0.75"	Engineering plastic
8	55412367	2	Membrane seal for Ø 0.75"	EPDM
9	55410246	2	Strap assy.	316 Stainless steel
10	55410352	2-3	Saddle	Engineering plastic

Notes:

- 1) Items 9 & 10 are optional. Delivered upon request. Priced separately.
- 2) Number of elements can vary between 1-6 for membrane length of 40", or 1-12 for membrane length of 21".
- 3) Items 6, 7 & 8 are not used for in the vessels with 1 or 2 membrane elements.
- 4) Item 3 corresponds to membrane elements with permeate tube 0.75".
- 5) Items 7 & 8 can be changed to fit more types of membrane permeate tube.
- 6) Item 7 for permeate tube Ø 0.75", part number of Blind adapter - 001-075-1208.

3.3.- BEL 4" Pressure vessel 600 psi. End Port type.

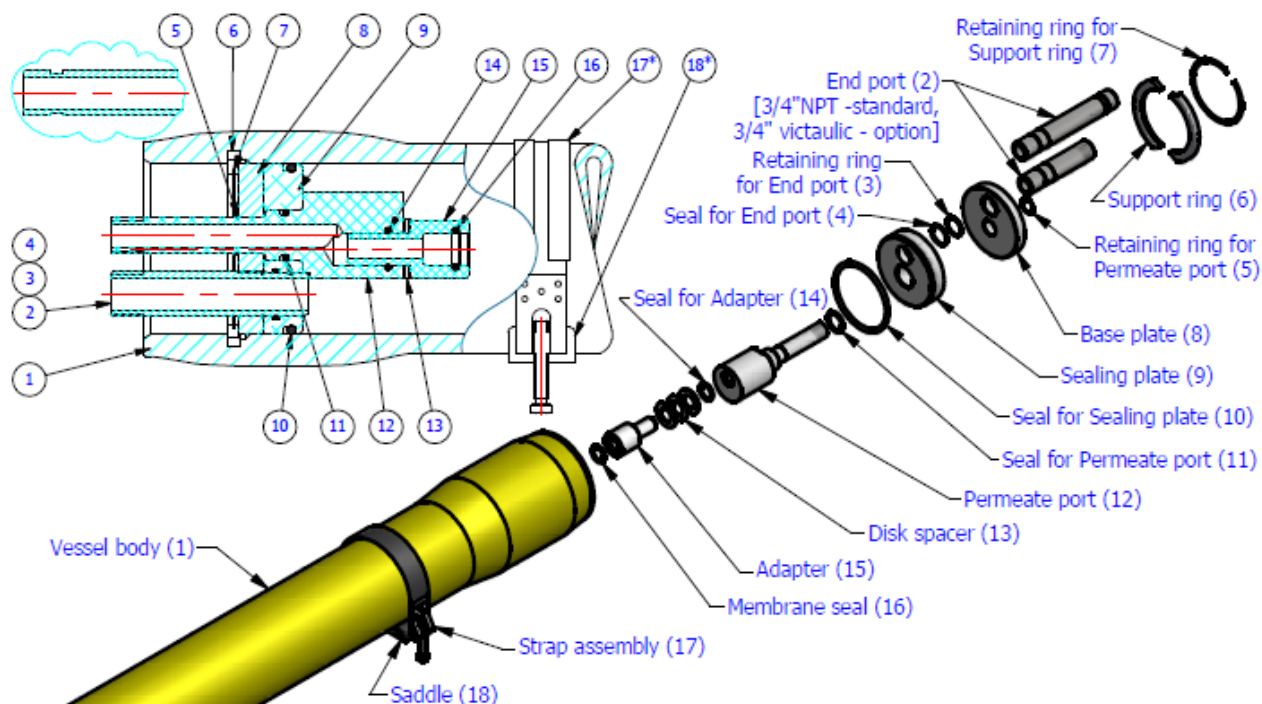

Item	Part number	Q-ty	Description	Material
1	40600-/0..6(12)	1	Body of Pressure vessel	Glass / Epoxy
2	009-034-0600	2	End port 3/4" NPT	316 Stainless steel
3	011-034-1202	2	Retaining ring for E. port	316 Stainless steel
4	55412361	2	Seal for port	EPDM
5	55412369	2	Retaining ring P. port	316 Stainless steel
6	005-461-1200	2	Support ring	Aluminum
7	011-401-1202	2	Retaining ring	316 Stainless steel
8	003-400-1003	2	Base plate	Aluminum
9	55410231	2	Sealing plate	Engineering plastic
10	55412360	2	Seal for S. plate	EPDM
11	55412363	2	Seal for P. port	EPDM
12	008-403-1200	2	Permeate port	Engineering plastic
13	55412377	0-6	Disk spacer	Engineering plastic
14	55412367	2	Seal for Adapter	EPDM
15	001-075-1200	2	Adapter for Ø 0.75"	Engineering plastic
16	55412367	2-4	Membrane seal for Ø 0.75"	EPDM
17	55410246	2	Strap assy.	316 Stainless steel
18	55410352	2-3	Saddle	Engineering plastic

Notes:

- 1) Items 17 & 18 are optional. Delivered upon request. Priced separately.
- 2) Number of elements can vary between 1-6 for membrane length of 40", or 1-12 for membrane length of 21".
- 3) Items 15 & 16 can be changed to fit more types of membrane permeate tube.
- 4) Item 15 for permeate tube Ø 0.75", part number of Blind adapter - 001-075-1208.
- 5) Item 2 with Victaulic connection, part number 009-134-0600.

3.4.- BEL 4" Pressure vessel 1000 psi. End Port type.

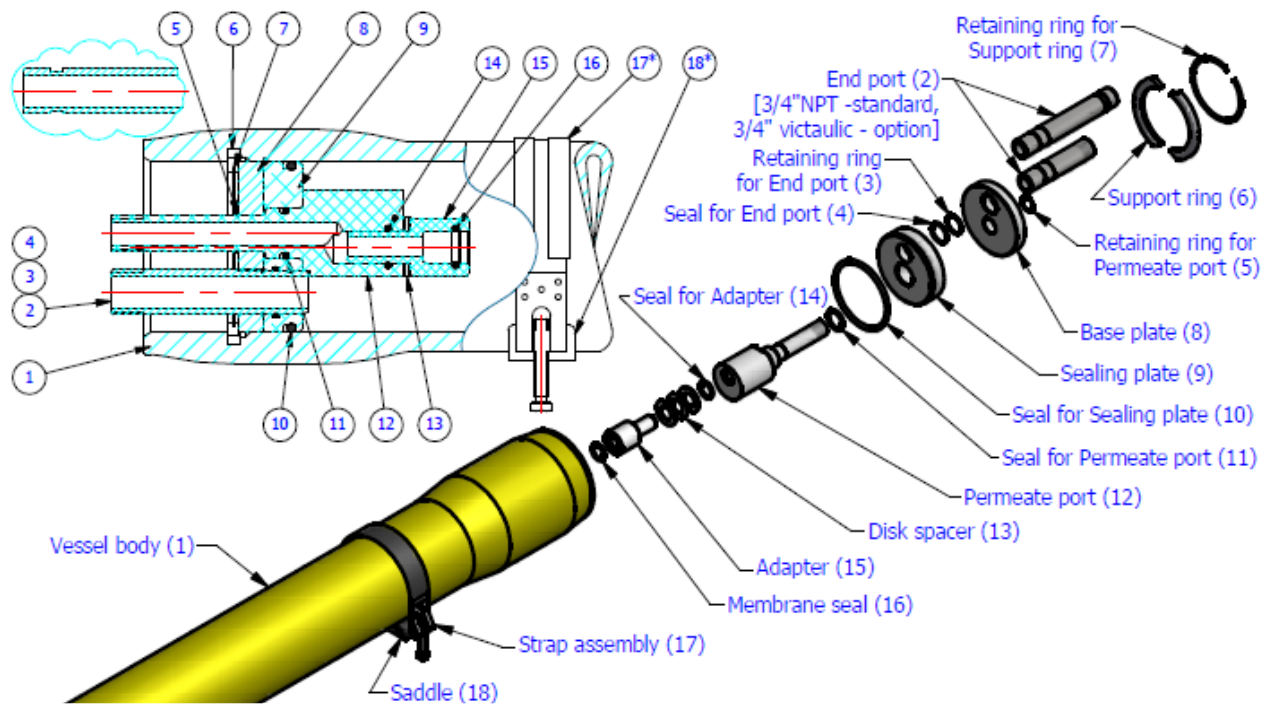

Item	Part number	Q-ty	Description	Material
1	401000-/0..6(12)	1	Body of Pressure vessel	Glass / Epoxy
2	009-034-1200	2	End port 3/4" NPT	Super Duplex Stainless steel
3	011-034-1202	2	Retaining ring for E. port	316 Stainless steel
4	55412361	2	Seal for port	EPDM
5	55412369	2	Retaining ring P. port	316 Stainless steel
6	005-461-1200	2	Support ring	Aluminum
7	011-401-1202	2	Retaining ring	316 Stainless steel
8	003-400-1003	2	Base plate	Aluminum
9	55410231	2	Sealing plate	Engineering plastic
10	55412360	2	Seal for S. plate	EPDM
11	55412363	2	Seal for P. port	EPDM
12	008-403-1200	2	Permeate port	Engineering plastic
13	55412377	0-6	Disk spacer	Engineering plastic
14	55412367	2	Seal for Adapter	EPDM
15	001-075-1200	2	Adapter for Ø 0.75"	Engineering plastic
16	55412367	2-4	Membrane seal for Ø 0.75"	EPDM
17	55410246	2	Strap assy.	316 Stainless steel
18	55410352	2-3	Saddle	Engineering plastic

Notes:

- 1) Items 17 & 18 are optional. Delivered upon request. Priced separately.
- 2) Number of elements can vary between 1-6 for membrane length of 40", or 1-12 for membrane length of 21".
- 3) Items 15 & 16 can be changed to fit more types of membrane permeate tube.
- 4) Item 15 for permeate tube Ø 0.75", part number of Blind adapter - 001-075-1208.
- 5) Item 2 with Victaulic connection, part number 009-134-1200.

3.5.- BEL 4" Pressure vessel 1200 psi. End Port type.

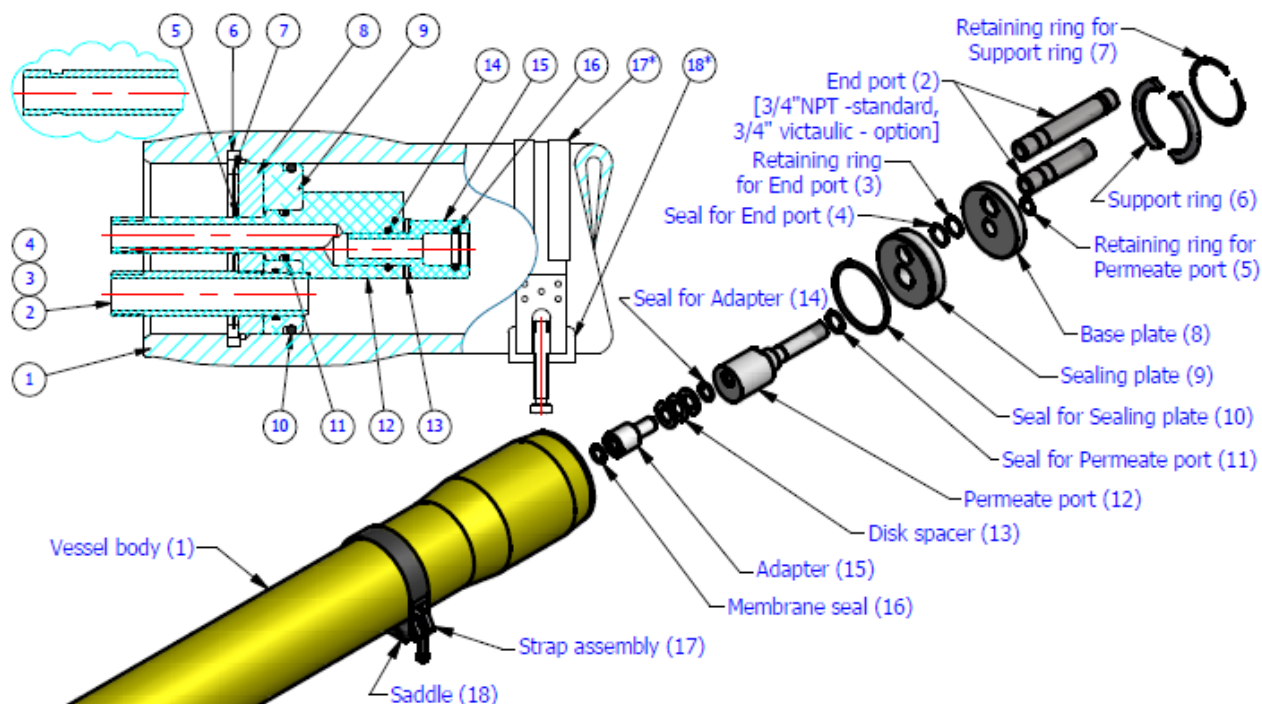

Item	Part number	Q-ty	Description	Material
1	401200-/0..6(12)	1	Body of Pressure vessel	Glass / Epoxy
2	009-034-1200	2	End port 3/4" NPT	Super Duplex Stainless steel
3	011-034-1202	2	Retaining ring for E. port	316 Stainless steel
4	55412361	2	Seal for port	EPDM
5	55412369	2	Retaining ring P. port	316 Stainless steel
6	005-461-1200	2	Support ring	Aluminum
7	011-401-1202	2	Retaining ring	316 Stainless steel
8	003-400-1003	2	Base plate	Aluminum
9	55410231	2	Sealing plate	Engineering plastic
10	55412360	2	Seal for S. plate	EPDM
11	55412363	2	Seal for P. port	EPDM
12	008-403-1200	2	Permeate port	Engineering plastic
13	55412377	0-6	Disk spacer	Engineering plastic
14	55412367	2	Seal for Adapter	EPDM
15	001-075-1200	2	Adapter for Ø 0.75"	Engineering plastic
16	55412367	2-4	Membrane seal for Ø 0.75"	EPDM
17	55410246	2	Strap assy.	316 Stainless steel
18	55410352	2-3	Saddle	Engineering plastic

Notes:

- 1) Items 17 & 18 are optional. Delivered upon request. Priced separately.
- 2) Number of elements can vary between 1-6 for membrane length of 40", or 1-12 for membrane length of 21".
- 3) Items 15 & 16 can be changed to fit more types of membrane permeate tube.
- 4) Item 15 for permeate tube Ø0.75", part number of Blind adapter - 001-075-1208.
- 5) Item 2 with Victaulic connection, part number 009-134-1200.

3.6.- BEL 4" Pressure vessel 1500 psi. End Port type.

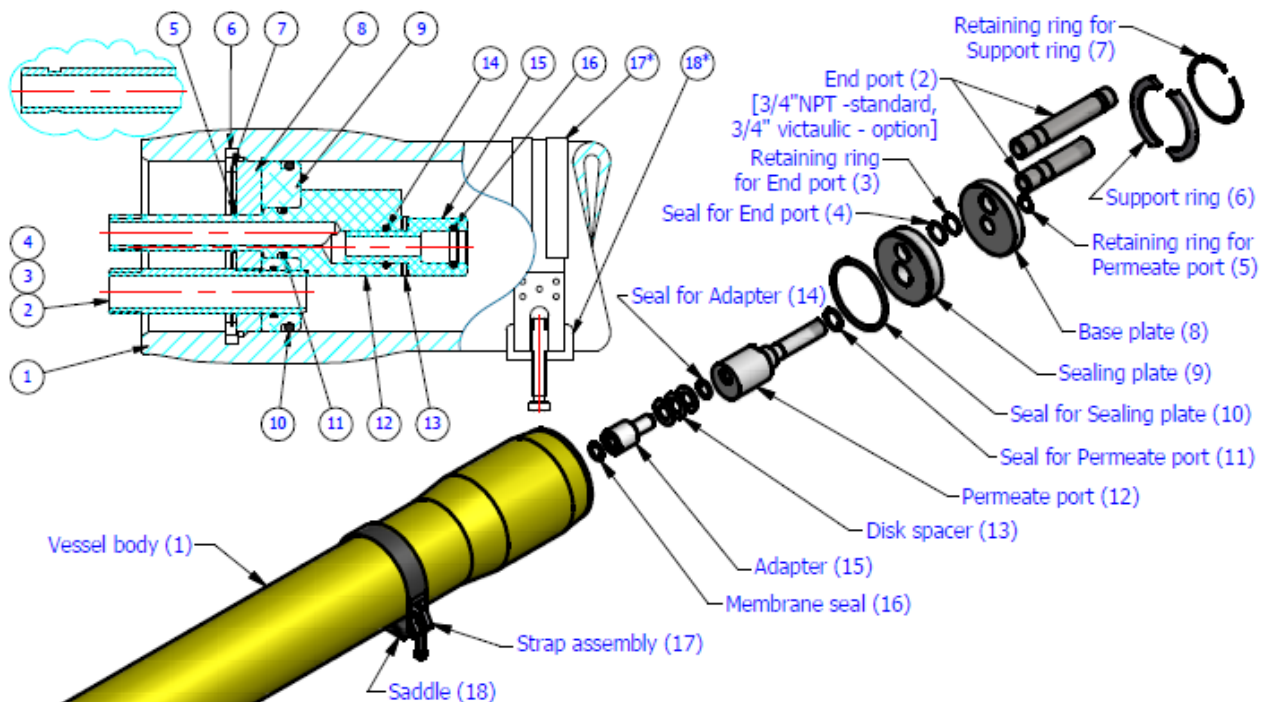

Item	Part number	Q-ty	Description	Material
1	401500-/0..6(12)	1	Body of Pressure vessel	Glass / Epoxy
2	009-034-1200	2	End port 3/4" NPT	Super Duplex Stainless steel
3	011-034-1202	2	Retaining ring for E. port	316 Stainless steel
4	55412361	2	Seal for port	EPDM
5	55412369	2	Retaining ring P. port	316 Stainless steel
6	005-461-1500	2	Support ring	316 Stainless steel
7	011-401-1202	2	Retaining ring	316 Stainless steel
8	003-423-1003	2	Base plate	316 Stainless steel
9	55410231	2	Sealing plate	Engineering plastic
10	55412360	2	Seal for S. plate	EPDM
11	55412363	2	Seal for P. port	EPDM
12	008-403-1200	2	Permeate port	Engineering plastic
13	55412377	0-6	Disk spacer	Engineering plastic
14	55412367	2	Seal for Adapter	EPDM
15	001-075-1200	2	Adapter for Ø 0.75"	Engineering plastic
16	55412367	2-4	Membrane seal for Ø 0.75"	EPDM
17	55410246	2	Strap assy.	316 Stainless steel
18	55410352	2-3	Saddle	Engineering plastic

Notes:

- 1) Items 17 & 18 are optional. Delivered upon request. Priced separately.
- 2) Number of elements can vary between 1-6 for membrane length of 40", or 1-12 for membrane length of 21".
- 3) Items 15 & 16 can be changed to fit more types of membrane permeate tube.
- 4) Item 15 for permeate tube Ø0.75", part number of Blind adapter - 001-075-1208.
- 5) Item 2 with Victaulic connection, part number 009-134-1200.

4. MAINTENANCE

4.1.- Opening the vessel

4.1.1. **Pressure relieve** - Stop all pumps and relieve pressure from vessel.

4.1.2. Disconnect all pipes from ports connecting the vessel's heads with the manifolds.

4.1.3. **300/450 psi vessels** - Use a flat-end screwdriver. Insert the blade underneath the tab of the spiral retaining ring locker and pull out the end of the spiral. Pull the spiral's end towards the center of the head and outwards until the whole length of the spiral retaining ring has been extracted.



600/1000/1200 psi vessels - Use a flat-end screwdriver. Insert the blade underneath the tab of the spiral-retaining ring, lift it up and pull it out of the groove, by running your screwdriver behind the retaining ring as it continues to exit the groove, as shown in pictures. Once the retaining ring is out, remove the two locker segments from the groove.



4.1.4. head extraction -

a- Tight the puller legs (see annex 1) to the vessel wall as shown in Fig 4.1.4a to support the puller to the vessel.

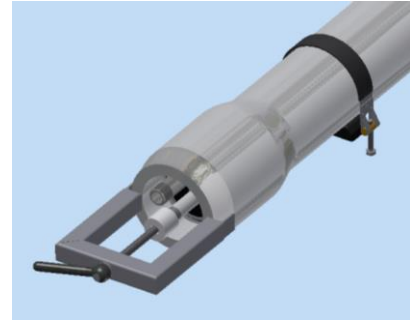

Fig 4.1.4a

b- Screw in fully the cup to the Permeate port (clockwise) while supporting the back side of the puller.

c- Screw out the Puller's handle (clockwise) until the Head assembly is extracted, after that pull out the Puller with the Head assembly. As shown in Fig 4.1.4b

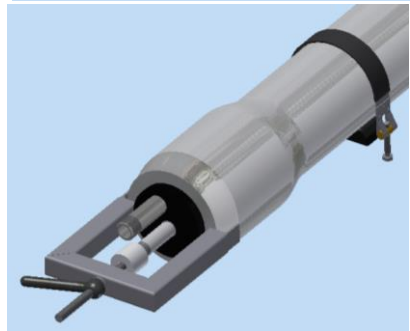

Fig 4.1.4b

4.2.- Visual inspection

Once the vessel has been opened, perform a visual inspection of the vessel, head and fittings, to locate any signs of corrosion or salt concentrations if corrosion or salt concentrations are found, follow the following steps:

Component inspection

- 4.2.1 Use a small wire brush to loosen any large deposits.
- 4.2.2 Place components in a shallow container of soapy water and scrub their surfaces with medium-grade Scotch-Brite until all corrosion is removed.
- 4.2.3 Rinse components with clear water.
- 4.2.4 Blow components dry with compressed air.
- 4.2.5 Examine components for damage that may affect structural strength or sealing properties.

Vessel inspection

- 4.2.6 If any case of deposit of foreign material has been discovered scrub surface with a fine Scotch-Brite and a mild detergent solution, clean both ends of the vessel, up to 30 cm into the vessel for 300/450 psi & 45 cm for 600/1000/1200 psi.
- 4.2.7 If during inspection scratches are found on the inner surface of the vessel, grind the area carefully with sand paper until it is smooth.

Note! DO NOT strike or apply excessive force on the ports to remove the vessel's head.

Note! if the vessel was in service for a long time, it may be more difficult to remove the head assembly.

4.3.- Closing the vessel

4.3.1. Clean vessel internal surface area with clean clamp cloth. Ensure vessel sealing area is smooth and free of scratches. Please consult BEL in case of scratches. Clean head seal or replace with new (recommend after opening). Apply full and reach layer of lubricant on the O-ring (the amount of the lubricant should be just enough to give a lustre to the O-ring) and on the vessel's groove and sealing area. See pictures.



4.3.2. Place the pusher (see Annex 1) and push the Head into the vessel on its place. To avoid property damage do not bend the tool inside the Base plate Permeate port.

4.3.3. With the head assembly inserted into the vessel (once the head is in the correct position, the groove for support ring is exposed) slide the two segments into the locking groove (for 600/1000/1200 psi vessels) as shown in Figs 4.3.3.1, 4.3.3.2.



Fig 4.3.3.1



Fig 4.3.3.2

4.3.4. Insert the retaining ring into the groove of the Support ring and continue running your fingers behind the retaining ring as it continues to enter the groove. As shown in Figs 4.3.3.3, 4.3.3.4, 4.3.3.5.



Fig.4.3.3.3.



Fig.4.3.3.4



Fig.4.3.3.5

For 300/450 psi vessels must be used only Retaining ring without Support ring.



4.4.- Head disassembly

4.4.1. Disassemble the Adapter and Spacers from the Sealing plate by removing it out from the plate (for 300/450 psi vessels) or from the Permeate port (for 600/1000/1200 psi vessels).



4.4.2. Use a screwdriver in order to remove the retaining ring, which hold the Base plate to its place. As shown in pictures.



4.4.3. Disassemble the Permeate port from the Base/Sealing plate by pressing the threaded end of the permeate port, as shown in Fig 4.4.3 and Fig 4.4.4. After remove the Sealing plate from the Base plate, Fig 4.4.5.



Fig 4.4.3



Fig 4.4.4



Fig 4.4.5

4.4.4. Use a screwdriver in order to remove the retaining ring, which hold the End port that installed at the inner side of the Base plate, as shown in pictures.



4.4.5. Remove seal from the grooves:

a) Seal for Sealing plate for 300/450 psi vessels and for 600/1000/1200 psi vessels



b) Seal for End port for 600/1000/1200 psi vessels



c) Seal for Permeate port for 600/1000/1200 psi vessels



d) Seal for Adapter for 300/450 psi vessels and for 600/1000/1200 psi vessels



e) Membrane seal for 300/450 psi vessels and for 600/1000/1200 psi vessels.

4.4.6.



4.5.- Head reassembly

Parts for vessel 300/450 psi.

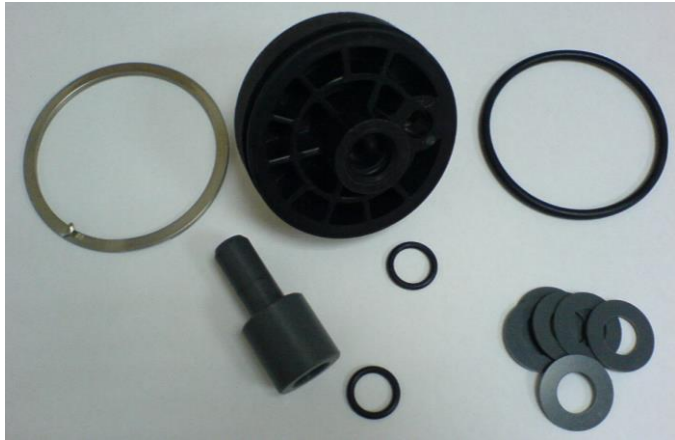

Parts for vessel 600/1000/1200 psi.



4.5.1. Install the O-ring seals on the Sealing plate into the groove (Seal for Sealing plate & Membrane seal), Permeate port and Adapter. Visually check the seals for any mechanical damage.

a) for vessel 300/450 psi.



b) for vessel 600/1000/1200 psi.



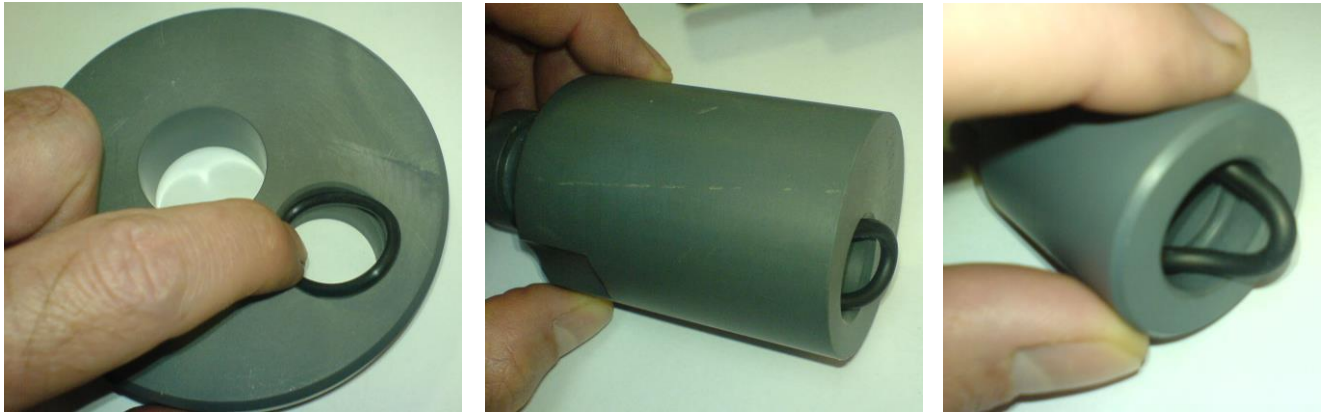

4.5.2. Apply a small amount of lubricant (Molykote 111 or equivalent, Glycerin can be used as well) on the seals (Seal for End port, Seal for Permeate Port and Adapter seal).

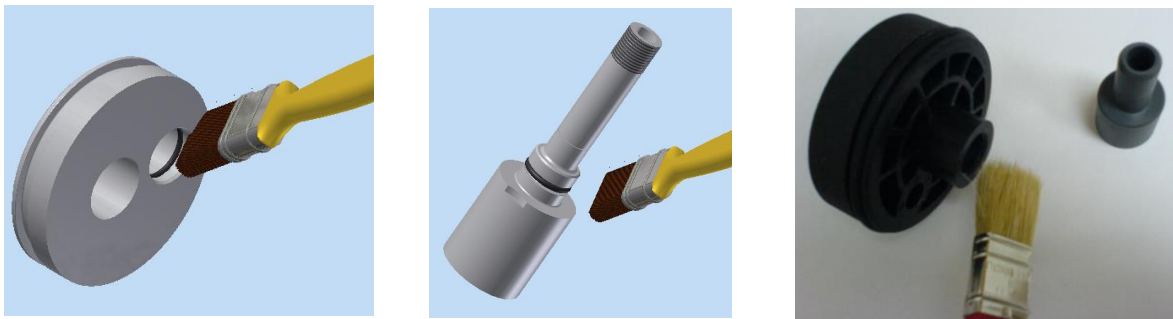

4.5.3. Insert the End port into the Base Plate, as shown in Fig 4.5.3.1 and use a screwdriver to install the internal retaining ring until it fits the End port groove. After install the retaining ring in the external side of the Base plate to hold the End port.



Fig 4.5.3.1

4.5.4. When the Base plate and the End port installed, couple both parts with Sealing plate by pushing them together until they touch each other.

4.5.5. Insert the Permeate port from the inner side of the base plate and carefully push it all the way, as shown in Fig 4.5.5.



Fig 4.5.5



- 4.5.6. Install the retaining ring as shown in Fig 4.5.6 in order to secure the Permeate port to place.

Fig 4.5.6



- 4.5.7. Apply a thin layer of lubricant (Molykote 111 or equivalent, Glycerin can be used as well) on the Adapter seal thereafter insert the Adapter into the Permeate port (with a plastic / rubber mallet).

For 300/450 psi



For 600/1000/1200 psi

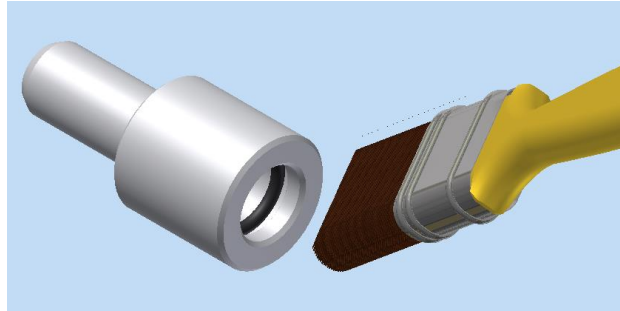

Or can be added the Spacers for head used in feed side (see ANNEX 2 for Shimming procedure).

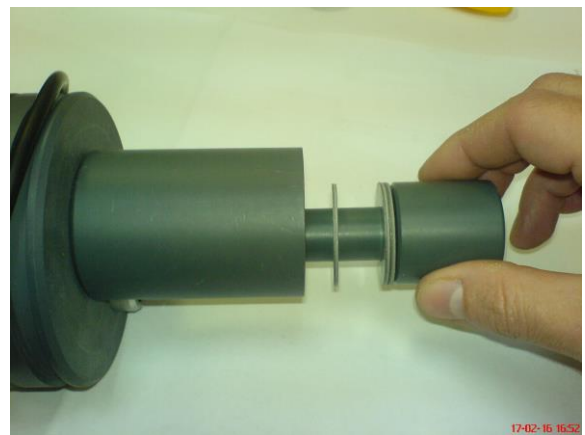

Note: for vessel closing, apply a small amount of lubricant on the seals (Seal for sealing plated and Membrane seal) and on the vessel's groove and sealing area (see §4.3).



4.6.- Loading the membrane elements

4.6.1. Flush the vessel with fresh water to remove dust and debris.

4.6.2. Insert Head assembly, **without the O-ring** into the downstream end of the vessel.

4.6.3. Install the segments of the support ring into the locking groove.

4.6.4. Inspect the membrane element surface to find any imperfections that could scratch the vessel bore element loading. If any defect is found, which cannot be easily corrected contact the element manufacturer.

4.6.5. Apply a thin layer of lubricant (see §4.3) to lubricate the inside of the vessel near the groove. **This will assist membrane element loading and reduce the risk of inadvertently scratching the vessel bore.**

4.6.6. Install the brine seal on the upstream end of the membrane element so that the seal's open side faces upstream (if it is not already installed by the manufacturer). Apply a thin layer of lubricant on the seal.

4.6.7. Load the first element into the upstream of the vessel. Leave 10 cm of the element projecting out of the vessel to facilitate connection with the next element.

4.6.8. Apply a small amount of lubricant (see 4.5) onto the O-ring of the interconnector and connect the interconnector to the projected end of the loaded element.

4.6.9. Line up the next element and assemble it to the inter connector which is already on the first element. **Carefully maintain element alignment during assembly, misalignment may result damage to the membrane and vessel parts.**

4.6.10. Carefully push the two elements into the vessel until the second element is projecting from the vessel approximately 10 cm. Repeat the above steps until all membrane elements have been assembled.

4.6.11. Calculate the correct shimming distance (see Annex 2) in order to avoid impact damage on the membrane and head parts during pressure drop.

4.6.12. Insert the shimming spacers on the upstream head assembly (Membrane adapter) so that the sum of their lengths will be equal to the shimming distance.

4.6.13. Install the upstream head assembly as described in section 4.3.

4.6.14. Remove the downstream head assembly and reassemble it with the O-ring.

ANNEX 1 - BEL Puller For 4" pressure vessels heads extraction

This tool designated to extract BEL head assembly for 4" pressure vessels. Before opening any of the vessels parts ensure internal pressure has been unloaded.

Note:

It is highly recommended to replace all seals each time the head is reassembled.

Part number: 069-040-1200 –for vessels 600/1000/1200 psi,
069-040-0450 – for vessels 300/450 psi.

Kit assembly: Tool must be assembled as shown on illustration 1.

Figure 1 –Puller assembly

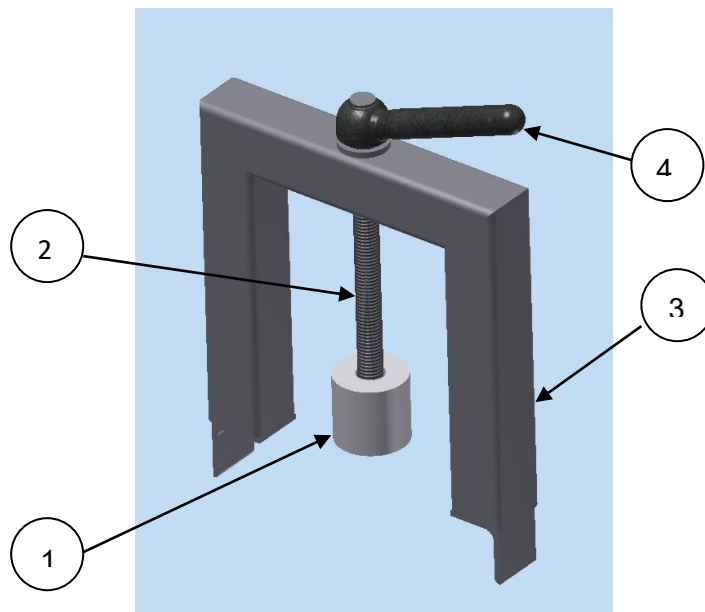

(1) Puller adapter, (2) Threaded Rod

(3) Puller base, (4) Handle

ANNEX 2 - BEL Pusher For 4" and pressure vessels heads installation

This tool designated to install BEL head assembly for 4" and pressure vessels.

Note:

It is highly recommended to replace all seals each time the head is reassembled.

A seal replacement kit is available from **BEL's** Customer Service.

For Head installation apply full and reach layer of lubricant on seals, vessel's groove and vessel's sealing area.

Part number: N/A – can be used Plastic (PVC, PP) pipe for head installation.

Pipe dimensions: O.D.= 100 mm., I.D.=80 mm., Length=150 mm.

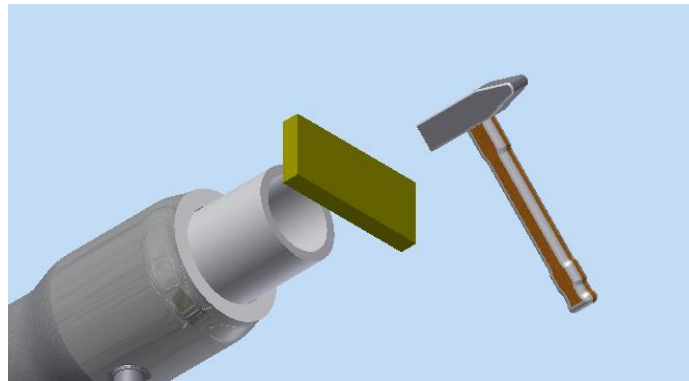

ANNEX 3 - Shimming procedure

Correct shimming is needed in order to keep minimum Adapters and Membrane elements movement at operation time, **shimming should be applied at the feed side only.**

First, make sure the membranes is fully pressed towards the brine side. Load the head assembly and the membranes. In order to check that the membrane is fully pressed against the brine side, pull out the head assembly and measure the distance between the membrane and the locker (See "Y" in the drawing below).

This distance is equal to the total length of the head assembly - 87 mm for 300/450 psi vessels or 135 mm for 600/1000/1200 psi vessels. It is important to mention that measuring of "Y" is an option and it's not mandatory. However it is very important* to make sure that the membrane is fully pressed before applying the shimming procedure.

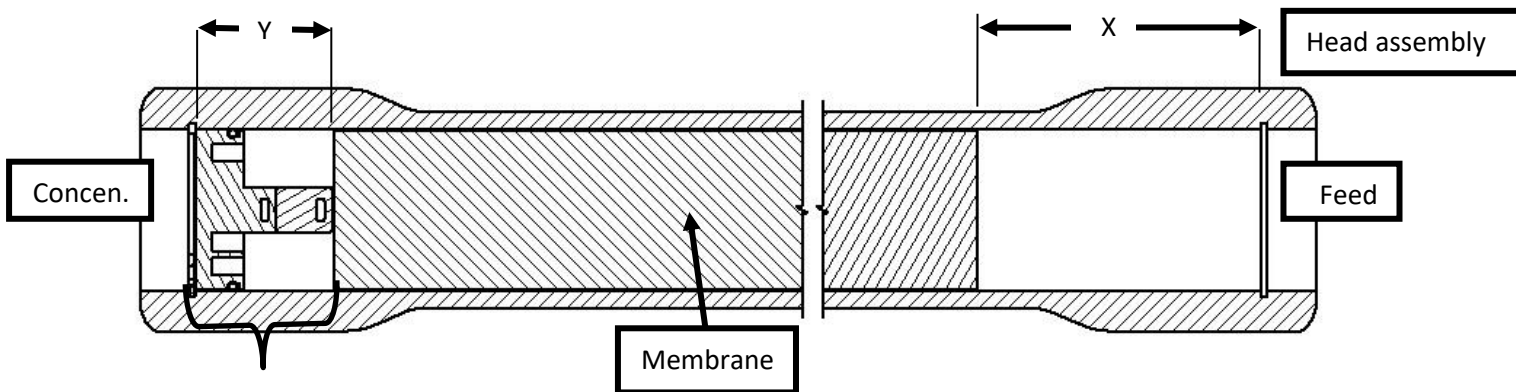

Correct shimming can be achieved by using the following formulas:

For BEL 4" 300/450 psi:

Let X (see drawing above) be the distance between the groove and the membrane on the feed side. Measure this distance by using a caliber between the inner side of the locker and membrane.

$$\text{Shimming} = X - t_{\text{base plate}} - t_{\text{adapter}} - 2 = X - 50 - 35 - 2 \Rightarrow X - 87 \text{ [mm]}$$

$t_{\text{base plate}}$ - Thickness of base plate

t_{adapter} - Thickness of adapter

* Note: this process is highly recommended for vessels containing 3 membranes and above.

For BEL 4" 600/1000/1200 psi-

Let X (see drawing above) be the distance between the inner side of the locker and the membrane on feed side.

$$\begin{aligned} \text{Shimming} &= X - t_{\text{sealing plate}} - t_{\text{base plate}} - t_{\text{permeate port base}} - t_{\text{adapter}} - 2 \\ &= X - 23 - 15 - 60 - 35 - 2 \Rightarrow x - 135 \text{ [mm]} \end{aligned}$$

$t_{\text{sealing plate}}$ - Thickness of sealing plate

$t_{\text{base plate}}$ - Thickness of base plate

$t_{\text{permeate port base}}$ - Thickness of permeate port base

t_{adapter} - Thickness of adapter

After installing the shimming, a space of 1 mm to install the retaining ring locker / locker shall remain. In case of extra space or too little space, remove or add spacers respectively until receiving a satisfying result.

ANNEX 4 - O-Ring replacement and scratches treatment procedure

1. Preparations

Please prepare the following items before procedure:

- 1.1. New intact O-Ring seal suitable with Base/Sealing Plate type.
- 1.2. BEL Base/Sealing Plate. Ensure O-Ring groove is clean and free of scratches.
- 1.3. Clean cloth.
- 1.4. Lubricant.
- 1.5. BEL Pusher/Puller (optional).

2. O-Ring Replacement procedure

- 2.1. Clean vessel internal surface at sealing area (O-Ring area) with clean damp cloth after the dissembling of the head assembly from the vessel.
- 2.2. Ensure vessel sealing area is smooth and free of scratches. See next procedure for scratch treating.
- 2.3. Assemble Head parts (e.g. Base Plate, Sealing Plate, Permeate Port, Adapter, O-Rings and Shims) and apply full and reach layer of lubricant on seals, vessel's groove and vessel's sealing area.
- 2.4. Install Head using BEL's pusher.

3. Scratches treatment procedure

- 3.1. Clean vessel internal surface at sealing area (O-Ring area) with clean damp cloth.
- 3.2. Locate the scratch at the O-Ring sealing area. Scratches out of this area will not cause leaks, therefore will not be treated.
- 3.3. Grind out the scratch using Extra-Fine sand paper (P400) until scratch is flat and smooth. DO NOT grind deep into the vessel; this might cause permanent damage to the vessel.

Note: In case of deep scratches or layers delamination please consult BEL engineering department.